

LOSS CONTROL DATA GUIDE

## Punch Presses

### Guarding – Punch Presses:

Unguarded punch press operations have long been responsible for numerous and serious employee injuries. However, no longer should it be necessary or permissible to expose employees to unguarded press operations. Today, there are effective point of

operation guarding methods for practically every setup. The proper type of guarding arrangement will not only prevent punch press accidents but will also result in improved operating efficiency. The following are typical punch press guarding methods:

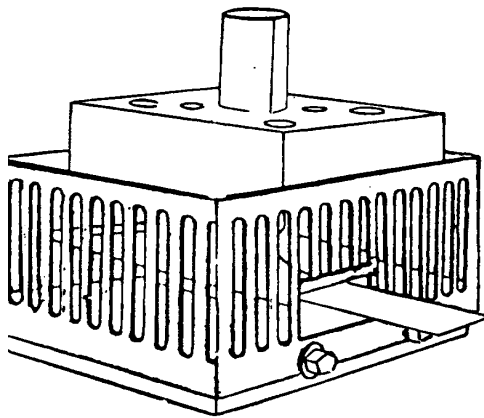

Enclosure Guard

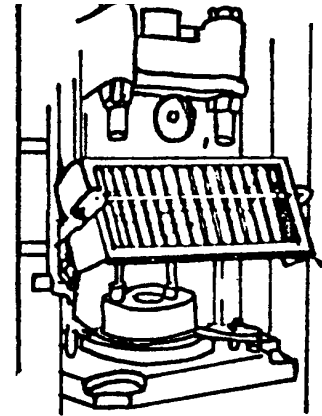

Gate guard on punch press. Guard is interlocked with tripping device of press so that plunger cannot descend until gate is in closed position.

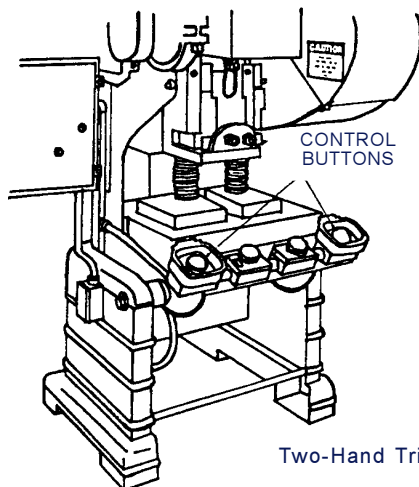

Two-Hand Trip

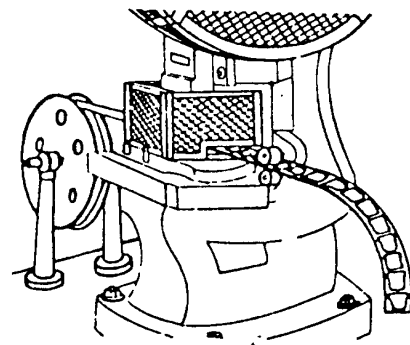

Automatic feed. Stock is fed automatically to plunger, operator required only to restock feeding device.

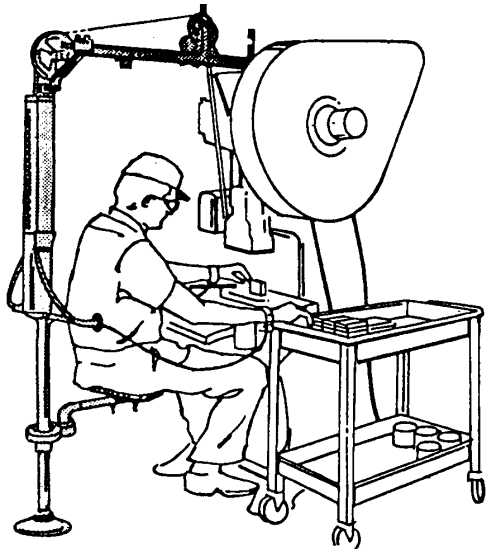

Hand Removal Guard. Operator's hands are pulled away from danger zone before ram descends.

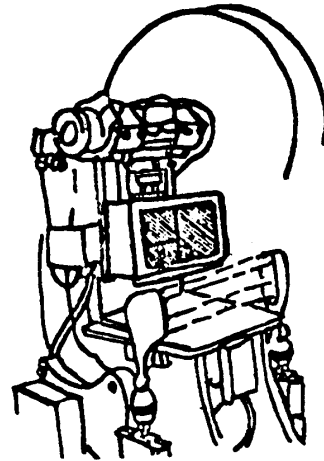

Electronic Beam prevents operation of press while operator's hands are in the danger zone. Should not be used on positive clutch presses where ram continues its stroke after tripping of press.

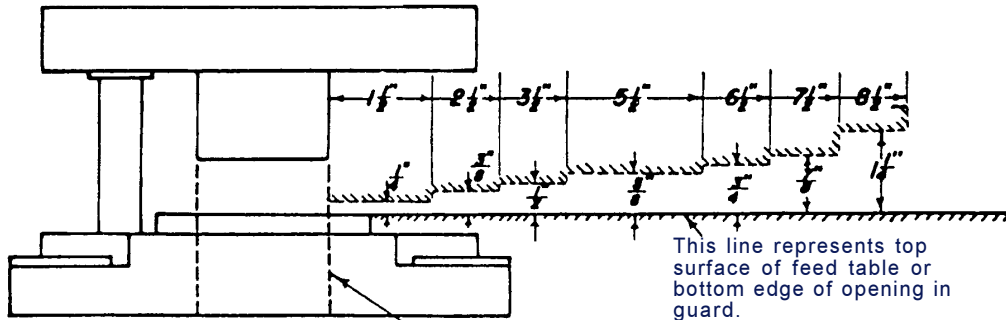

Limited Opening. If ram stroke is limited to 1/4 inch, enclosure is unnecessary. When enclosure of die is necessary, size of openings should not exceed that shown for various distances.

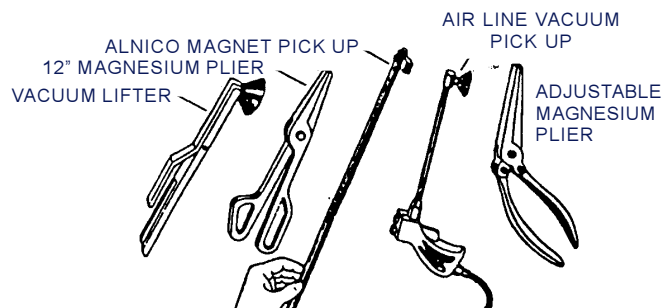

Special Tools. The use of specially designed hand-tools for placing material into the press will provide additional protection.

The loss prevention information and advice presented in this brochure are intended only to advise our insureds and their managers of a variety of methods and strategies based on generally accepted safe practices, for controlling potentially loss producing situations commonly occurring in business premises and/or operations. They are not intended to warrant that all potential hazards or conditions have been evaluated or can be controlled. They are not intended as an offer to write insurance coverage for such conditions or exposures, or to imply that Great American Insurance Company will write such coverage. The liability of Great American Insurance Company is limited to the specific terms, limits and conditions of the insurance policies issued.